

NEW

SUCTION CUP

SUCTION CUP (EP SPONGE TYPE)

■ Suction Cup (EP Sponge type)



VC-ES

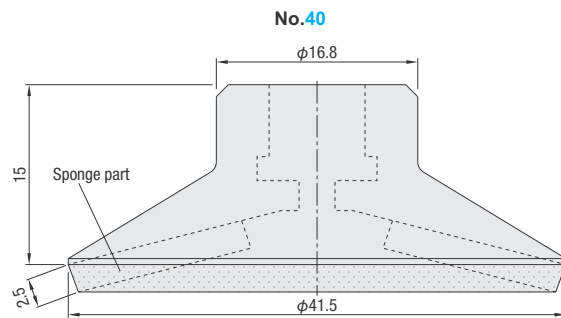
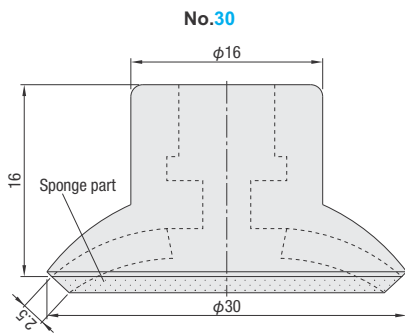
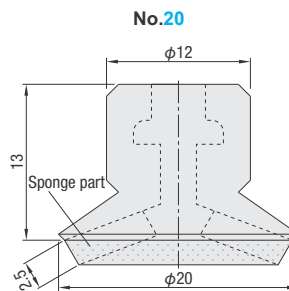
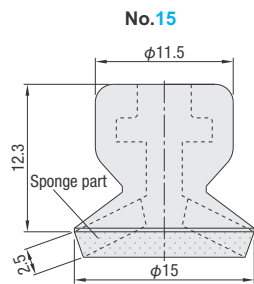

Body: Silicone
 Sponge: EDPM silicone
 Shore A50~70
 Specification Temperature -70°C~200°C
 Maximum Operating Temperature 80°C

Applicable metal fittings	Mounting type	Cup dia.	Weight (g)*1	Part Number		Unit Price
				Type	No.	1~30 pcs
VC-KNG7 VC-KNGB7	Embedded type	15	1	VC-ES	15	Quotation
		20	1		20	
VC-KNG11 VC-KNGB11		30	3		30	
		41.5	5		40	

*1 The weight is an approximate value which serves only as a guideline.



Order

Part Number
VC-ES30



Days to Ship

Quotation



Price

Quotation

SUCTION METAL FITTING

SUCTION BRACKET

— SCREW MOUNTING / CYLINDER MOUNTING TYPE —

VC-KNG (Screw mounting type)

M Material
 Body: A6061
 Spring: Carbon steel
 Fitting / Stop plug: SUM22 equivalent

S Surface treatment
 Body: White alumite
 Fitting / Stop plug: Electroless nickel plated

Applicable tube Outer×Inner: 6×4

A Accessory
 Pipe fitting: 1 pc
 (Applicable tube 4×2.5)

REMOVAL RELATED PRODUCTS

Applicable cup	Weight (g) ^{*1}	L	E	J	K	Q	Part Number		Stroke	Unit Price
							Type	D		
VC-SP4-SP25	8	41	5	2.5	5	13	VC-KNG	7	5	Quotation
VC-NS8,12	9	46							10	
VC-ES15,20	10	56							20	
	11	66							30	
VC-SP30-SP50	8	44	8	4.2	8	16		11	5	
VC-HSP	9	49							10	
VC-NS15-NS40	10	59							20	
VC-ES30-ES40	11	69							30	

Part Number — **ST**
VC-KNG11-ST20

Days to Ship **Quotation**

Price **Quotation**

*1 The weight is an approximate value which serves only as a guideline. ^② For quantities not displayed here, refer to our MISUMI website for more information.
^① A ϕ 5 fitting (connected to tube outer diameter 6×4) is attached to the suction bracket body. A ϕ 3.6 fitting is also included as an accessory, to allow switching according to the specifications.