

Linear Bushing Housing Units with Dowel Holes

Wide Blocks - Single / Double

= For customers selecting MISUMI original specifications =
The products on this page are of standard specifications (Outer cylinder SUJ2 equivalent, Retainer resin). Consider these specifications while selecting the product.

■ Features: MISUMI original. Dowel Hole Type reduces machine assembly time and improves locating repeatability.

MISUMI Original

Single



Double



RoHS10

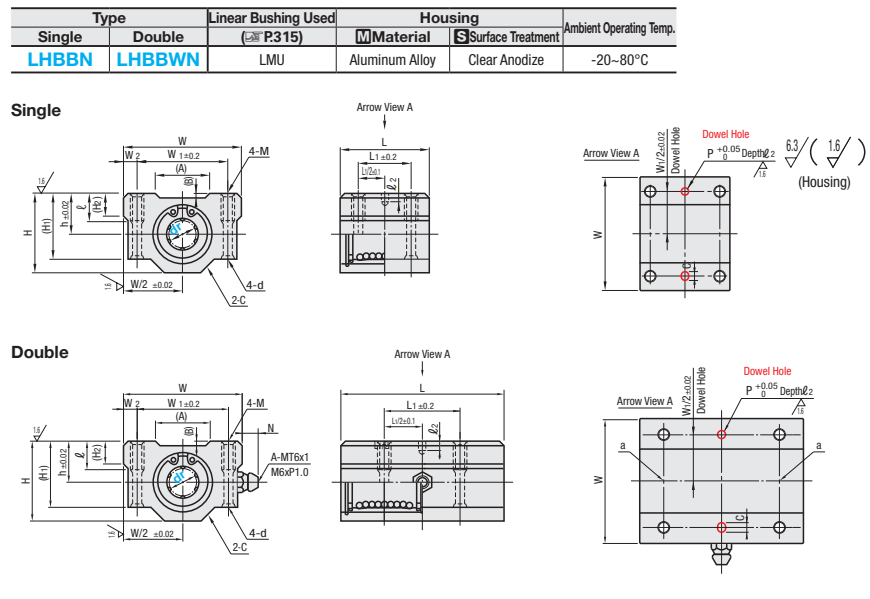

dr	Tolerance		L		L1		h	H	(H1)	(H2)	W	W1	W2	M	d	ℓ	(A)	(B)	N	C
	Single	Double	Single	Double	Single	Double														
10			35	68	21	46	13	26	21		40	28	6	M5	4.3	12	15.5	0.4	7.5	5
12	0	0	36	70			28	24	8	42	30.5	5.75	17.5				7			
13	-0.009	-0.010	39	75	26	50	15	30	24.5		44	33	5.5			19	0.85	6.5	5.5	
16			44	85	34	60	19	38.5	32.5	9	50	36	7			19.8			6	
20			50	96	40	70	21	41	35	11	54	40		M6	5.2		21	0.5	7.5	6
25	0	0	67	130	50	100	26	51.5	42	12	76	54	11				36	1	4.5	9.5
30	-0.010	-0.012	72	140	58	110	30	59.5	49	15	78	58	10				39.9	0.75	5.5	10.5
35			80	155	60	120	34	68	54	18	90	70		M8	7	18	53		6	14
40	0	0	90	175	60	140	40	78	62	20	102	80					61	1.5		16
50	-0.012	-0.015	110	215	80	160	52	102	80	25	122	100	11	M10	8.7	25	81		5.5	22

⚠ For Precautions for Use, see P.303 ⚠ Inner surfaces of dowel holes are not anodized.
⚠ There will be dowel holes on "a" locations for dr50. ⚠ The datum surface is located on the other side of product ID label. ⚠ Dowel Pins MS and MSC on P.2-239 are recommended.

Linear Bushing Housing Units with Dowel Holes

Tall Blocks - Single / Double

= For customers selecting MISUMI original specifications =
The products on this page are of standard specifications (Outer cylinder SUJ2 equivalent, Retainer resin). Consider these specifications while selecting the product.

■ Features: MISUMI original. Dowel Hole Type Type reduces machine assembly time and improves locating repeatability.

MISUMI Original

Single



Double

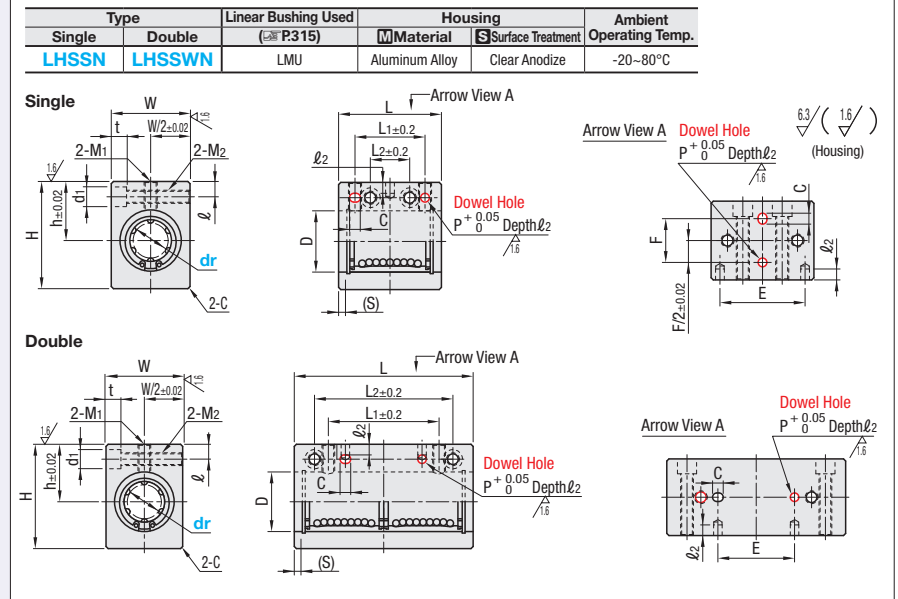

dr	Tolerance		D	(S)	L		L1		L2		h	W	H	ℓ	M1 (Effective Length)	M2 (Effective Length)	d1xt	C
	Single	Double			Single	Double	Single	Double										
8			15	3.0	32	56	20	30	10	42	16	20	26	5	M5 (8.5)	M4 (15)	6x5	1
10			19		39	68	27	36	15	50	19	26	32	6	M5 (20)	M5 (20)	8x6	
12	0	0	21	4.0	40	70					20	28	34	6	M6 (9.5)	M5 (22)	8x6	
13	-0.009	-0.010	23		42	74	28	42	16	55	25	30	43	7	M6 (23)	M6 (23)	9x7	
16			28	3.8	47	84	32	52	18	65	27	36	49	7	M6 (29)	M6 (29)	9x7	
20			32		52	94	36	58		70	31	42	54	8	M8 (15)	M8 (34)	11x8	
25	0	0	40	3.2	69	128	42	80	22	100	37	52	65	9	M10 (17)	M10 (42)	14x10	
30	-0.010	-0.012	45		74	138	44	90		110	40	58	71	9	M10 (17.5)	M10 (48)	14x10	

⚠ For Precautions for Use, see P.303 ⚠ Make certain that the screws do not interfere with the bushing as M1 are through holes. ⚠ Position of dowel hole for Double Type is ±0.02 to center of dr.
⚠ The datum surface is located on the other side of product ID label. ⚠ Dowel Pins MS and MSC on P.2-239 are recommended. ⚠ Inner surfaces of dowel holes are not anodized.

Part Number	Unit Price	
	Single	Double
10	LHBBN10	LHBBWN10
12	LHBBN12	LHBBWN12
13	LHBBN13	LHBBWN13
16	LHBBN16	LHBBWN16
20	LHBBN20	LHBBWN20
25	LHBBN25	LHBBWN25
30	LHBBN30	LHBBWN30
35	LHBBN35	LHBBWN35
40	LHBBN40	LHBBWN40
50	LHBBN50	LHBBWN50

dr	Dowel Hole Dimensions			Basic Load Rating				Allowable Static Moment (N·m)		Mass (g)	
	P	ℓ2	C	C (Dynamic) N		Co (Static) N		Single	Double	Single	Double
				Single	Double	Single	Double				
10				372	588	549	1100	-	7.24	92	180
12				412	657	598	1200	-	10.9	102	205
13	4	5	5	510	813	784	1570	-	11.6	120	240
16				775	1230	1180	2350	-	19.7	220	400
20				882	1400	1370	2740	-	26.8	255	570
25				980	1560	1570	3140	-	43.4	600	1200
30	5	6	6	1570	2490	2740	5490	-	82.8	735	1480
35				1670	2650	3140	6270	-	110	1100	2200
40				2160	3430	4020	8040	-	147	1590	3200
50	6	7	7	3820	6080	7940	15900	-	397	3340	6700

kgf=Nx0.101972

Ordering Example
Part Number
LHBBN10 (L Type Greased)
LHBBWN20 (G Type Greased)
LHBBWN20L (H Type Greased)
LHBBWN20H (H Type Greased)
Alternative grease types available.
For Days to Ship, Price and Performance, see P.304

■ Feature of Dowel Hole Type
• By the dowel holes provided on the mounting interface surface, locating work using the side datum can be eliminated. (See Installation Example on right)
• Machining work can be reduced for the top plate to be mounted on the block.

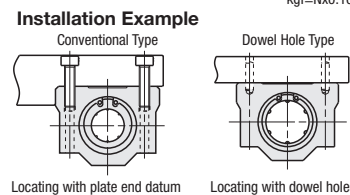

Ordering Example
Part Number
LHSSN16 (L Type Greased)
LHSSWN20L (G Type Greased)
LHSSN16G (H Type Greased)
LHSSWN20H (H Type Greased)
Alternative grease types available.
For Days to Ship, Price and Performance, see P.304.

■ Features of Dowel Hole Type
• By the dowel holes provided on the mounting interface surface, locating work using the side datum can be eliminated. (See Installation Example on right)
• Machining work can be reduced for the top plate to be mounted on the block.

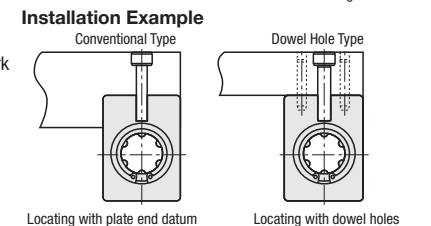

kgf=Nx0.101972