

Locating Pins

Air Vent, Threaded / Tapped

■ Features: Air vent enables easy insertion of pins.

Material	Hardness	Type	
		Threaded	Tapped
SUJ2	Treated Hardness: 45 - 50HRC	LPN	LPT
SUS304 Equivalent	-	SLPN	SLPT
SUS440C Equivalent	Treated Hardness: 50 - 55HRC	CLPN	CLPT

• Threaded

• Tapped

RoHS 10

Part Number		D dim. Tolerance g6	L						L1	d _{g6}	M (Coarse)	Tightening Torque N·cm	l ₁	l ₂	r	Unit Price			
Type	Material Code		10	12	15	20	25	30								LPN	SLPN	CLPN	
LPN SLPN CLPN	5	-0.004 -0.012	10	12	15	20	25	30	12	3	-0.002 -0.008	M3	147	7	1	1			
	6		10	12	15	20	25	30	15	4		M4	333	10					
	8	-0.005 -0.014	10	12	15	20	25	30	20	5		M5	676	1.5	1.5				
	10		15	20	25	30			20	6	-0.004 -0.012	M6	1156	15	2	2			
	12	-0.006 -0.017	15	20	25	30													

⊕ L=10, 12 are applicable to SLPN and CLPN only.
 * Tightening torque (reference) will be within Strength Class of Tightening Torque on Technical Data P. 2297 (10.9). Not applicable when using locking materials or lock washers.

Part Number		D dim. Tolerance g6	L						M (Coarse)	Tightening Torque N·cm	l ₁	l ₂	r	Unit Price		
Type	Material Code		10	12	15	20	25	30						LPT	SLPT	CLPT
LPT SLPT CLPT	5	-0.004 -0.012	10	12	15	20	25	30	M3	147	6	1	1			
	6		10	12	15	20	25	30	M4	333	8					
	8	-0.005 -0.014	12	15	20	25	30		M5	676	8	1.5	1.5			
	10		20	25	30				M6	1156	10	2	2			
	12	-0.006 -0.017	20	25	30											

⊕ l₁=6 only when D=6, L=10. The pilot hole for tapping may go through.
 * Tightening torque (reference) will be within Strength Class of Tightening Torque on Technical Data P. 2297 (10.9). Not applicable when using locking materials or lock washers.

Ordering Example

Part Number	-	L
LPN5	-	15
LPT6	-	20

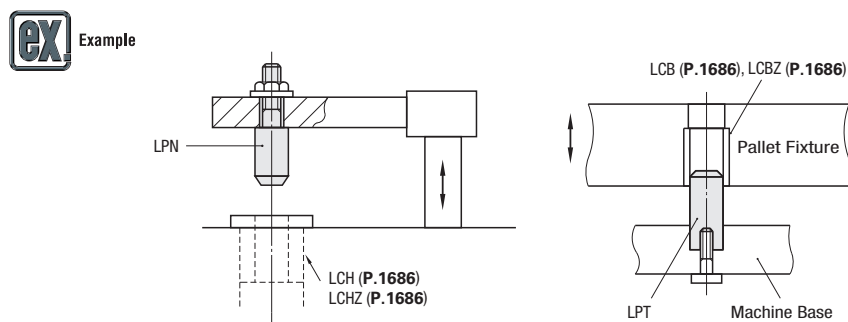

Locating Pins

Plastic, Small Diameter / Plastic, Screw Mounted

■ Features: Having a metal core, it is less prone to be broken when used for side locating. Characteristic of Resin P.2-953, 954

Part Number	Material Code	Material	d	K
			0.4	8.5
			0.7	10
			1.0	16

Core Rod Length
 Straight, Sphere: The smaller of the followings. L-(D/2+2) or the value of row K in the table above
 Straight, Flat: The smaller of the followings. L-(2) or the value of row K in the table above
 Small Head: The smaller of the followings. (L+B)-(P/2+2) or the value of row K in the table above

⊕ Some combinations are not available. Refer to the price list to select the available combination.
 ⊕ Core rod material is SUS304.
 ⊕ There is a flat part of Ø0.2 or below at the tip of Straight, Sphere and Small Head Type.
 ⊕ MC Nylon of flat is not available.
 ⊕ The outer diameter tolerance is the result of measurement at room temperature (20°C).

• Plastic, Small Diameter

RoHS 10

• Straight, Sphere

• Straight, Flat

• Small Head

Part Number		D 0.1mm Increment	D dim. Tolerance m6	L 0.5mm Increment	d	Unit Price						
Insertion Guide Shape	Material Code					SNSBB	SNSPM	SNSFC	SNSPK	SPSBB	SPSPM	SPSPK
SNS (Sphere)	BB PM EC PK	1.0~2.0	+0.008 +0.002	5.0~20.0	0.7							
SPS (Flat)		2.1~3.0			1.0							

Part Number		D Tolerance	D 0.01mm Increment	L 0.1mm Increment	d	Unit Price			
Insertion Guide Shape	Material Code					SNPBB	SNPMP	SNPEC	SNPBK
SNP	BB PM EC PK	M (m6)	1.00~2.00	5.0~20.0	0.7				
		G (g6)	2.01~3.00		1.0				
		H (h7)							

Part Number		D 0.1mm Increment	D dim. Tolerance m6	L 0.1mm Increment	P 0.1mm Increment	B 0.1mm Increment	d	Unit Price			
Insertion Guide Shape	Material Code							SNSHBB	SNSHPM	SNSHEC	SNSHPK
SNSH	BB PM EC PK	1.1~2.0	+0.008 +0.002	5.0~18.5	1.0~1.9 (D>P)	1.5~10.0 (B-P/2≥1.0)	0.4				
		2.1~3.0			1.0~2.9 (D>P)		0.7				

⊕ When D≤2, L+B≤15 When D>2, L+B≤20

Ordering Example

Part Number	-	D	-	L	-	P	-	B
SPSBB	-	D1.5	-	L7.5	-		-	
SNSHPM	-	D1.5	-	L10.0	-	P1.0	-	B1.5

Part Number		P (Standard Grade)	P (Precision Grade)	B 1mm Increment	m	d ₁	d ₂	l	Applicable Screw	Unit Price		
Type	No.									1mm Increment Tolerance	0.1mm Increment Tolerance	JPAJ
JPAJ JPEAJ	FPAJ FPEAJ	3	8~10	0	8.0~10.0	0	10~25	2	6.5	3.5	4.5	M3
		4	10~12	0	10.0~12.0	0	15~35	3	8.0	4.5	5.5	M4
		5	12~16	0	12.0~16.0	0	15~50	4	9.5	5.5	6.5	M5

⊕ Characteristics of Polyacetal and PEEK P.2-953, 954

Ordering Example

Part Number	-	P	-	B
JPAJ3	-	P8	-	B15

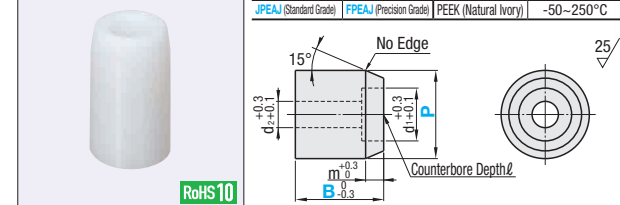

Plastic, Screw Mounted

RoHS 10